



SPECIAL FUNCTIONALITY IN E³.schematic

- Schematic creation
- Multi-language GUI
- Multiple drawing standards (e.g. IEC, DIN, ANSI, GOST)
- Multiple sheet formats (e.g. DIN and Ladder)
- Automatic text translation
- Comprehensive search mechanisms
- Context-sensitive online help
- 256 display levels
- Supports STEP, DXF/DWG, SVG and PDF pixel graphics
- Bidirectional API (COM/DCOM standard)
- Integrated component database editor
- Online terminal reports
- PLC import/export of I/O data
- Integrated electrical and fluid schematics
- Automatic contact arrangement tracking
- Configurable wire numbering
- Automatic and parallel connections
- Online design rule checking
- Variant and option support
- Online cross-references for connections and devices
- Configurable hyperlinks

E³.schematic - Documentation and creation of electrical schematics

Introduction

Zuken's E³.series is used for documenting and detailing electrical and fluid design projects. Its flexibility supports the entire process from definition and design, through manufacturing and maintenance. Its unique object-oriented architecture ensures all stages of the design are fully synchronized.

E³.schematic is the base module in the E³.series portfolio and provides electrical engineers with an easy-to-use solution for creating and documenting electrical control schematics.

E³.series' ECAD engine is designed by electrical engineers for electrical engineers. Features include integrated, real-time design rule checks (DRCs) to identify and prevent errors during the design phase, and an intelligent parts library that helps drive the design with automatic part selections.

Supported industries

E³.schematic is ideally suited for the machinery and power industries when used as a stand-alone module.

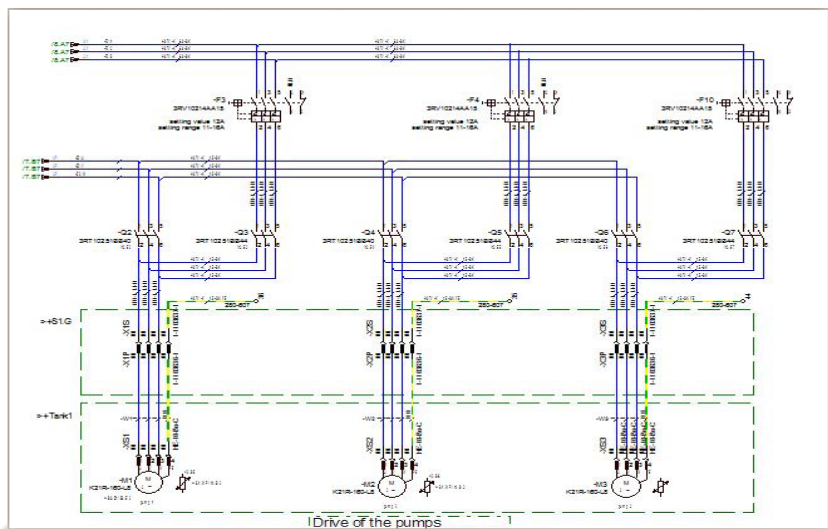

IEC drawing format

Scalable schematic creation

E³.series is a multi-sheet environment that can be scaled to meet all organizational requirements. E³.schematic Small Project Edition is ideal for customers whose designs do not exceed 30 schematic sheets. E³.schematic Professional is tailored for customers whose sheet count exceeds 30 but who only require single-user access. For larger companies requiring multi-user access, E³.schematic Enterprise supports a concurrent engineering model.

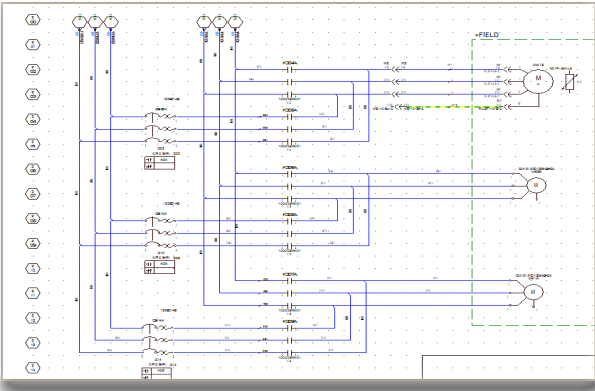

ANSI drawing format

Component-driven design

A feature unique to E³.series is its intelligent component library. Parts pulled from the component database include all symbols required by the engineer. For example, a contactor added to the design will include the correct coil and all auxiliary contacts, preventing use of hybrid, non-existent

parts. In the case of relays, users can easily see which contacts have been used and which are available. The online bill-of-materials and master references automatically track contact locations, speeding up the design process and improving accuracy.

Design rule checking

Core to E³.series are the built-in DRCs that include automatic part selection, duplicate device name prevention, short-circuit avoidance and incorrect wire gauge allocation. By preventing errors during the design phase, E³.series ensures design data is accurate prior to manufacturing.

Online terminal plan

Terminals added to the schematic are combined using an online terminal plan. Changes made in the terminal plan are immediately reflected across the design. This functionality saves time and allows for central management of terminal strips; users do not have to navigate through multiple schematic sheets. All terminal types are supported, including multi-stacking terminals.

IEC – ANSI standard support

E³.series supports multiple drawing standards and its library is pre-populated with symbols created in IEC and ANSI formats. E³.series also supports the IEC 61346 naming standards used in control system design in Europe, and the North American ladder standard with automatic part and wire naming based on sheet and ladder positions.

Additional E³.series options

E³.fluid

Integrated design solution for hydraulics, pneumatics, cooling and lubrication systems. Supports integrated electrical and fluid design.

E³.cable

Provides enhanced functionality for designing cables and cable harnesses. Different views of the design enable specific documents to be created for production, start-up and service.

E³.panel

For general arrangement drawings of cabinet enclosures. Work in either 2D or 3D, place devices, cable ducts and mounting rails and prepare panels for manufacture.

E³.formboard

Creates build-to-print detailed 1:1 harness designs; linked dynamically to E³.cable drawings.

E³.Revision Management

Document all physical and graphical changes between design iterations. Automatically produce engineering change order documentation.

E³.3D Routing Bridge

Transfer wire, cable and cable harness information to 3D MCAD systems. After routing, the individual wire lengths can be transferred back to E³.series.

E³.topology

Evaluate system harnesses early in the design flow for factors such as length, weight and cost. Enables tradeoff analysis of harnesses and sub-harnesses to optimize manufacturing performance and cost.

E³.redliner

Markup documents in a protected read-only copy of the design. Playback and jump to all recommended changes in the master design.

E³.view

View all E³.series projects and special viewer files with this free-of-charge viewer.